

Manual for Ecosoft Pink softeners



ECOSOFT PINK SOFTENER RANGE



Compact water softener

Part #	Description	Quantity of media, L
FU1013CABDVUP	Ecosoft Pink 10 compact water softener	10



Compact water softener

Part #	Description	Quantity of media, L
FU1016CABDVUP	Ecosoft Pink 15 compact water softener	15



Compact water softener

Part #	Description	Quantity of media, L
FU1024CABDVUP	Ecosoft Pink 20 compact water softener	20

CONTENTS

	1. Introduction	4
1.1	General provisions	4
1.2	Manufacturer	4
1.3	Safety rules	4
	2. Technical data	6
2.1	Cabinet dimensions	6
2.2	Pink series	7
	3. Delivery set	8
	4. Preparation of the installation site	9
	5. Procedure for installing an FU Cabinet system	9
5.1	Optional equipment	10
	6. Quick Set Up Guide	12
	7. Installation diagram	14
	8. Service	15
	9. Troubleshooting	16
	10. Guarantee	18
	11. Serial information	20



1. INTRODUCTION

1.1 General provisions

Filter installation should be carried out by a specialist with appropriate qualifications and experience. Children aged 8 years and older, as well as people with limited physical, sensory and mental abilities, with the lack of necessary knowledge and experience to use this device, they can use softener only under supervision and in compliance with the specified data security rules equipment and understand the hazards involved. Cleaning and user maintenance shall not be made by children without supervision. Do not allow children to play with the device!

If the softener is not used for a long time used: If you do not plan soon sometimes use the equipment (for example, during holidays) put it in bypass mode and turn it off it from the water supply network. For this it is necessary move the three taps to the opposite position (according to the installation section of this manual softener); or carry out the necessary procedures for using the Multiblock block (depending on what you are the one using it).

If the installation has not been used for a long time, we recommend softener regeneration in manual mode, in accordance with Section 4.2. given instructions Protection against extreme temperatures: Do not install the softener where it is joining it (including drainage pipes and overflow hose) can be exposed to temperature below 5°C or above 40°C.

1.2 Manufacturer

ECOSOFT 22
Industrieweg 8
3190, Boortmeerbeek
Belgie

ECOSOFT SPC LTD
Pokrovska 1st
08200, Irpin city, Kyiv region,
Ukraine

1.3 Safety rules

Electrical safety - we ask you use an adapter or battery (option) supplied with equipment Before using the device, check compatibility of the technical characteristics of the power supply unit with characteristics of the local power supply network.

A 50Hz 230V input voltage must be used to connect the water softener



Electric shock!

Danger to life due to electric shock.

Work with electrical equipment is allowed only to authorized service centers or qualified electricians who have been instructed

1. INTRODUCTION



Touching live parts can lead to electric shock

When carrying out service work with the control valve of the softener, turn off the power supply from the outlet

The power cord cannot be replaced. If the power cord is damaged, the appliance should not be used. If the power cord is damaged, please ask consultation with a qualified electrician. In the event of a power outage during regeneration, ensure the draining of wastewater into the drain. So BE SURE to connect to a softener overflow hose and drainpipes and connect them to suitable for this drainage / sewage system to avoid spillage of water in the room.

Warning: Do not use aggressive detergents. Wipe contaminated surfaces dry with a damp cloth.

Maintenance: When carrying out installation and technical works maintenance and repair of the softener isolate it. To make the softener last longer maintained good work results, necessary regularly carry out service work service. In more detail you can find out about it by contacting the nearest one partner service organization of the Ecosoft company



Pipelines of water softening systems are under pressure.

Before starting work with water softening systems, it is necessary to eliminate the pressure in the water supply

Opening threaded connections or taps can cause injury!

Unauthorized modification or changes to the system design may adversely affect the safety of people and the operation of the system

2. TECHNICAL DATA

2.1 Cabinet dimensions

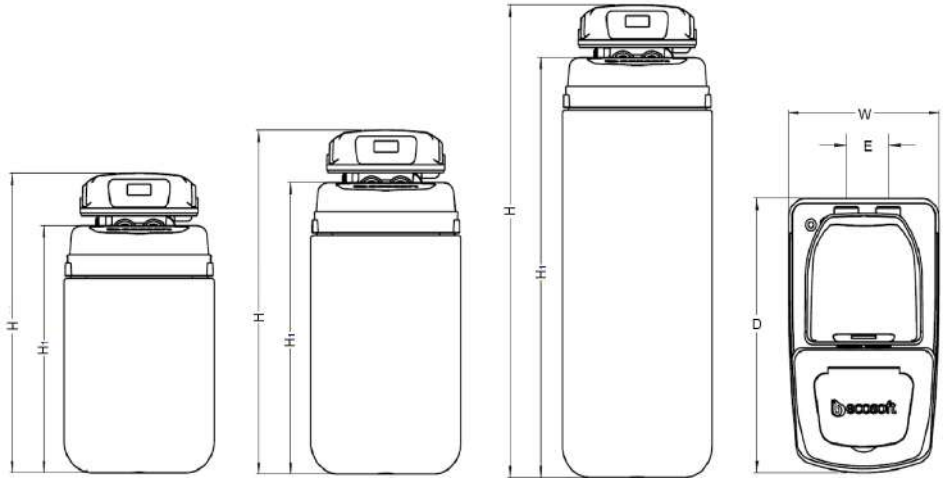

Model	Control valve port sizes (port height**, mm)					Dimensions*, mm			
	Water Inlet	Water Outlet	Drain Outlet	Brine Inlet	E (distance between Inlet / Outlet)	W	D	H	H ₁
FU1013CABDVUP	1" M (540)	1" M (540)	3/4" M (640)	3/8" CF (640)	78	270	430	469	387
FU1016CABDVUP	1" M (970)	1" M (970)	3/4" M (1070)	3/8" CF (1070)	78	270	430	539	457
FU1024CABDVUP	1" M (970)	1" M (970)	3/4" M (1070)	3/8" CF (1070)	78	270	430	741	659

2. TECHNICAL DATA

2.2 Pink series

TECHNICAL SPECIFICATION:

Parameter	FU1013CABDVUP	FU1016CABDVUP	FU1024CABDVUP
Operating flow rate, m ³ /h	1.2	1.5	1.8
Quantity of media, L	10	15	20
Volume capacity, m ³ @250 mg/L CaCO ₃ influent harness	2	3	5
Usage of salt per regeneration ¹ , kg	1.0	1.5	2.0
Usage of water per regeneration (= discharge per regeneration), m ³	0.08	0.1	0.12
Duration of regeneration, minutes	80–110		
Pressure drop in service mode, bar	0.5		
Inlet pressure, bar	2–6		
Electrical requirements	230 V, 50 Hz		
Power consumption, W	30		
Inlet/outlet pipe connections	3/4"		
Dry weight, kg	18.8	22.2	32.5
Overall dimensions, (Width × Depth × Height), cm	270 x 430 x 469	270 x 430 x 539	270 x 430 x 741

INFLUENT WATER LIMITATIONS:

Hardness	750 mg/L CaCO ₃
Iron	0.2 mg/L
Manganese	0.05 mg/L
Chemical Oxygen Demand	5 mg/L O ₂
Sediment prefilter rating	100 μm
Temperature of water ²	+4...+30 °C

3. DELIVERY SET

Ecosoft fabric softener comes in Kits with the following parts and blocks:

a) Softener body assembly

(includes pressure tank with media inside, Clack DV control valve)



Compact water softener

b) Connection kit



c) Plug connector for connection to power grids (EU)



d) Equipment passport



4. PREPARATION OF THE INSTALLATION SITE

- Installation area must meet all relevant building code. Water and power supply, and ambient conditions must meet Specification requirements of this manual.
- Observe all local plumbing and electrical code when connecting system to utilities.
- Install check valve when connecting the filter to water mains. Install second check valve after the system to prevent back flow.
- Particles such as sand, scale or rust can damage the control valve. Install a point-of-entry sediment filter.
- Equip the system with sampling taps and pressure gauges as shown on drawings. It will help in case any maintenance or troubleshooting is necessary.
- Install a vacuum relief valve as shown if there is a booster pump downstream of Ecosoft filter. The FRP tanks may implode if subjected to negative pressure.
- If your system does not include bypass valve assembly, run a bypass pipeline along the entire system. This may be necessary for diagnostics and maintenance.

5. PROCEDURE FOR INSTALLING AN FU CABINET SYSTEM

If your cabinet was delivered pre-loaded with media, place the cabinet in the installation spot, fill salt compartment with salt pellets, and then only carry out steps 5 – 8 of the procedure, skipping steps 1 – 4. If the resin was shipped in bag, then carry out all of the following steps.

1. Disconnect the flexible tube from brine inlet of the control valve. Unmount the valve by screwing it counterclockwise.
2. Put a plug or cap on the top end of the riser pipe to prevent getting any media inside the pipe. Pour the media in the tank using the funnel. When loading the tank, keep riser pipe vertical. If the pipe tilts, restore it to straight vertical direction. When finished, rinse the thread of tank opening with water to remove any beads of media stuck in the groove.
3. Mate the top distributor with the top end of riser pipe, then screw control valve in the tank opening. Connect the free end of brine tube back to the brine inlet of the control valve.
4. Place the cabinet in the installation spot. Open top lid and fill the salt compartment with softener salt pellets at least half full.
5. Connect drain pipe to the male threaded drain outlet of the control valve. Run the drain pipe to floor drain or gravity drain pipe socket. Secure the drain pipe end above the receiving fixture with at least 1" air gap.

5. PROCEDURE FOR INSTALLING AN FU CABINET SYSTEM

6. Mount the pipe thread elbow adapters to the control valve's In and Out ports and tighten the coupling nuts. Do not put any mechanical load on fittings or use them to support pipes.

Connect the system to water supply and downstream pipework without turning on the water supply. Do not confuse In and Out ports. They are embossed with direction arrows.

7. Remove the front panel by pulling the locking tabs on the left and right side. Run the power cord through the cord guide in the control valve's backplate and connect it to 12 VAC socket on the circuit board. Plug the power supply in the mains to power up the system.

8. Start manual regeneration of the system. Scroll regeneration to backwash if isn't the 1st step of the sequence. When the control valve starts the backwash, turn on mains water supply slightly at first. Air will be displaced from the system via drain line while the pressure tank is being filled with water. When the tank is full, water will start flowing down the drain line. At this point, fully open mains water supply.

Let the system complete regeneration, then perform one more manual regeneration.

5.1 Optional equipment

Softening systems can be additionally equipped with a Clack or Multiblock bypass valve.

The Clack bypass valve is attached directly to the inlet and purified water pipes and has 4 operating modes, listed below:

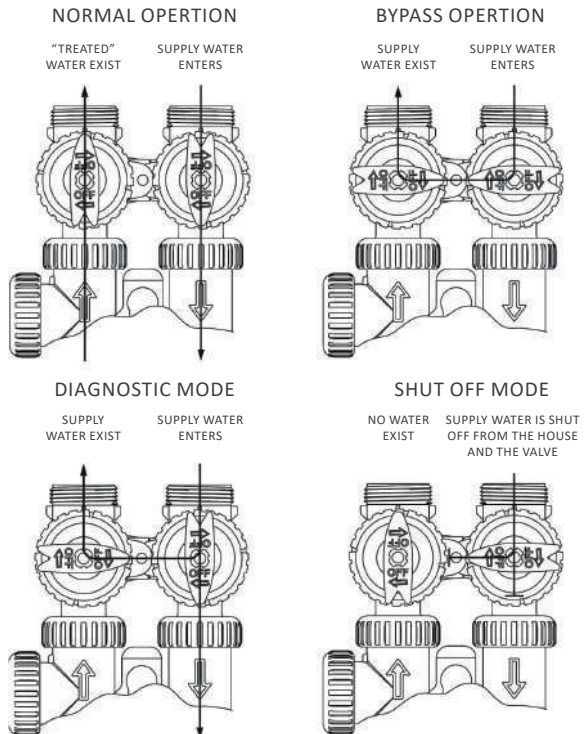

5. PROCEDURE FOR INSTALLING AN FU CABINET SYSTEM

The multiblock performs a bypass function, is equipped with a sampler and has 2 modes of operation:

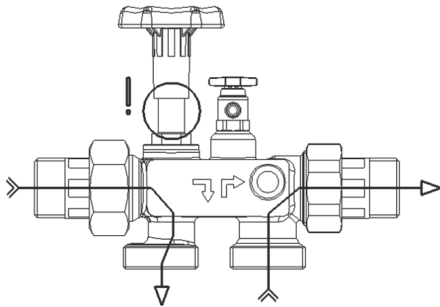

Open position — Supply via softener/limescale protection system: handwheel in UPPER position (stop)

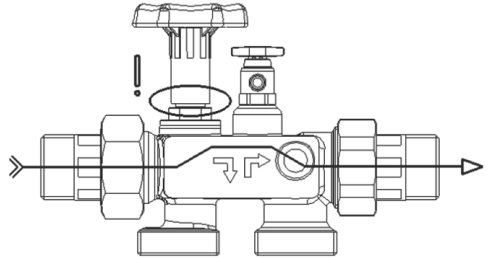

Bypass position — Supply via softener/limescale protection system: handwheel in LOWER position (stop)

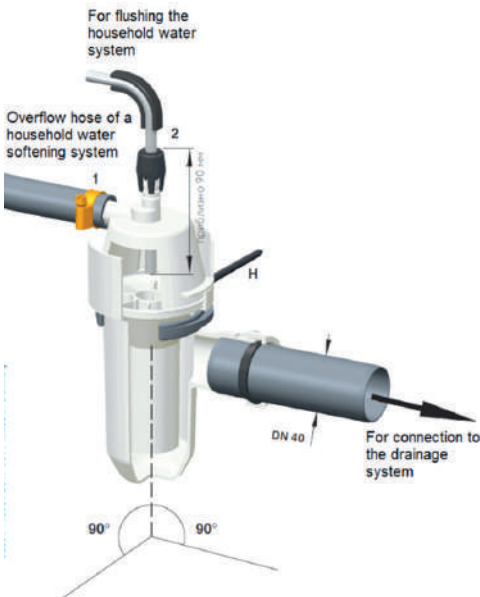

Place the fitting of the overflow hose (1) at least 20 mm below the height of the safety overflow of the domestic water softening system. Fix vertically with the bracket (H). Connect the flush water hose with a downward slope to the fitting (2) and insert to a depth of approx. 90 mm.

Connect the overflow hose from the brine tank to the fitting (1) and fix with a hose clamp.

The flush water hose and the overflow hose mustn't be connected and mustn't have narrowing in the cross section.

6 QUICK SET UP GUIDE

After installing and powering up an Ecosoft FU or FK system, set display language, water hardness, current time, and regeneration options in the **Installer** menu of control valve.

Use ▲ and ▼ buttons to change setting; NEXT button to save and go to next step; CLOCK to save and exit menu; REGEN to move back one step.

To proceed, hold NEXT and ▲ buttons simultaneously for 3 seconds.

STEP 11

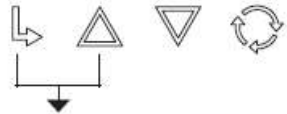

STEP 21

STEP 21. Hardness: Set the amount of hardness as calcium carbonate per PPM, using ▼ or ▲. Press NEXT to go to Step 41. Press REGEN to exit Installer Display Settings



STEP 31

STEP 31. Service Water Hardness (PPM): If a mixing valve is installed in the valve, service hardness needs to be set. Setting range is always less than the setting in Step 21. This screen will only appear if Step 4S is set to rES. Press NEXT to go to Step 41. Press REGEN to return to previous step.

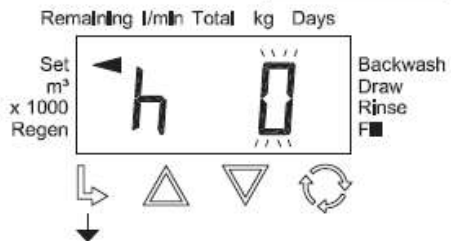

STEP 41

STEP 41. Set Day Override to 1 – 28 days or OFF using ▲ or ▼. Press NEXT to go to Step 51. Press REGEN to return to previous step.

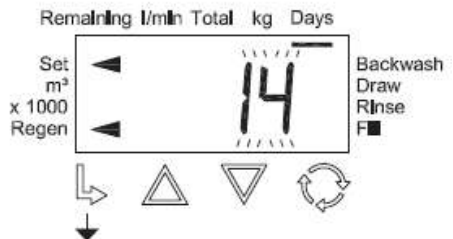

6 QUICK SET UP GUIDE

STEP 5I. Time of Regeneration, Hour: Set the time (hour) for regeneration using ▲ or ▼. The default time is 2:00 a.m. This display will show on 0 if Step 4S or Step 3F is set to on 0.
 Press NEXT to go to Step 6I. Press REGEN to return to previous step.



STEP 6I. Time of Regeneration, Minutes: Set the time (minutes) for regeneration using ▲ or ▼. The default time is 2:00 a.m. This display will not appear if Step 4S or Step 3F is set to on 0.
 Press NEXT to go to Step 7I. Press REGEN to return to previous step.



STEP 7I. Backlight Operation: Set the normal activity of the LCD backlight using ▲ or ▼. If value is set to:

- On, the backlight is always on.
- Off1, the backlight turns off after 5 minutes of no activity.
- Off2 + l/min, the backlight turns off after 5 minutes of no activity except with water flow detection.

Press NEXT to exit Installer Settings. Press REGEN to return to previous step.

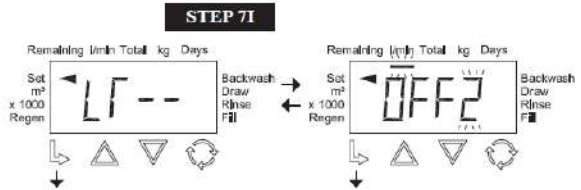

NORMAL MODE

7. INSTALLATION DIAGRAM

Compact water softener

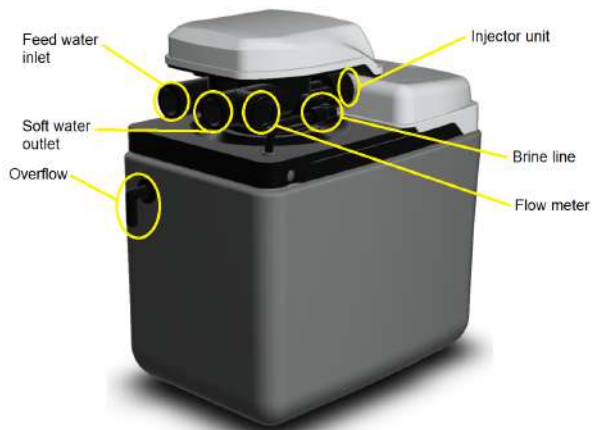
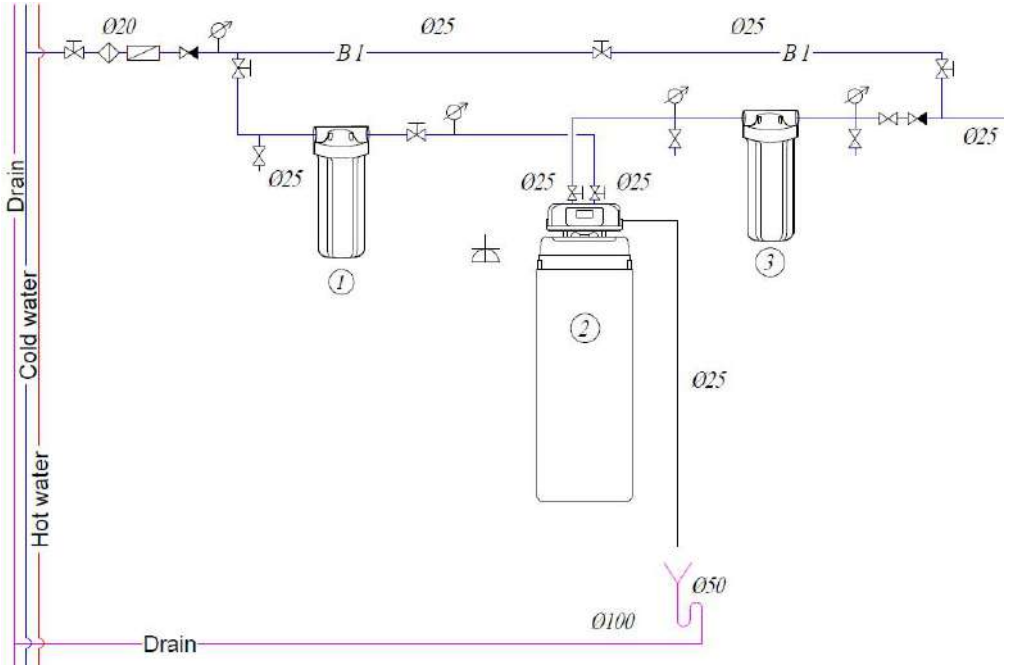

8. SERVICE

8.1 Maintenance work

To ensure proper operation softener, the user should regularly carry out the following checks:
Check the presence of salt and if necessary, add.

Check water hardness: hardness of drinking water and the hardness of mixed water should be checked no less than 2 times a year, if necessary, it should be adjusted the hardness of the mixed water (see the "Installation" section).

Check for tightness, carry out: visual inspection: check for possible leakage of all connections and pipelines. Check the cleanliness of the salt and saline solution storage capacity 1 time in 2 months, if necessary, clean and rinse clean water

The indicated terms of the recommended inspections are available are minimal and must be adjusted, depending on operating conditions.

8.2 User responsibility

Any technical equipment requires regular maintenance.

Constantly monitor the quality and level of softened pressure water If the water quality has changed, change it too parameter settings are set. If necessary, consult a specialist.

Regular checks by the operator are required as a guarantee normal functioning of the device. Emollient water should be regularly inspected compliance with the conditions of its operation.

Frequency of checks performed by the user:

After use: add salt for regeneration.

2 times a year: check the pressure

2 times a year: check water quality

Once a year: clean the salt tank

8.3 Service and spare parts

Parts that wear out must also be replaced in the specified maintenance period so that to guarantee flawless operation of the installation and perform warranty conditions. Softener maintenance it is recommended to carry out once a year.

Replacement of wearing parts can be performed only qualified personnel (specialists of the organization water supply or service).

We recommend concluding a service contract service with our service department.

Cleaning: do not use alcohol for cleaning or alcohol-based detergents to avoid damage surfaces of plastic parts.

8.4 Disposal

After the end of the service life of the installation contact Ecosoft Service to arrange softener replacement. Disposal of softener and of all electrical parts is carried out only in specialized recycling centers.

9. TROUBLESHOOTING

PROBLEM	CAUSE	CORRECTION
1. Decreased service flow capacity.	Decreased supply water pressure.	Increase supply water pressure.
	Clogged filter bed.	See paragraph 3.
	Obstructed/clogged drain line.	Clean the drain line.
	Clogged control valve.	Inspect and clean the control valve.
	NHWBP/MAV failure (if used).	Inspect and repair the motorized valve.
2. Decreased quality of treated water.	Faulty chemical analysis of water.	Perform one more test using freshly prepared reagents.
	Supply water chemistry has changed.	Make new check analysis and if changed contact your dealer.
	Bypass valve is set to bypass.	Turn bypass valve to operating position.
	Riser pipe or seals are damaged.	Take apart the filter, inspect and replace or lubricate pipe and seals if necessary.
	Clogged filter bed.	See paragraph 3.
	Filter media loss.	See paragraph 4.
	Improper filter regeneration.	See paragraph 6.
3. Clogged filter bed.	Insufficient backwash flow rate.	Check backwash flow rate. If supply pressure is within the limits and the flow rate is insufficient, inspect and clean the drain line flow control or replace it if needed.
	Insufficient backwash stage.	Increase the duration of backwash stage.
	Clogged top distributor.	Clean the top distributor.
	Excessive backwash flow rate.	Measure backwash flow rate. If supply pressure is normal and the flow rate is exceeding, consider changing the drain line flow control.
4. Filter media entrainment.	Filter media is entrained and discharged during backwash.	Replace the top distributor if needed.
	Filter media is entrained and discharged during service.	Replace the bottom distributor if needed.
5. System will not regenerate.	No electric power.	Check power supply.
	No/insufficient salt in brine tank.	Check the amount of salt in brine tank and add salt if needed.
	Brine is not sucked in during regen., or not all brine is drawn.	See paragraph 6.
	Control valve is out of order or settings were changed.	Check the control valve and its settings (see the manual for the control valve).
	Brine tank is not refilled or is refilled with not enough water.	See paragraph 7.

9. TROUBLESHOOTING

PROBLEM	CAUSE	CORRECTION
6. Brine will not draw during regeneration or not all brine will draw.	Low supply water pressure.	Check supply water pressure.
	Clogged injector or brine tube.	Clean brine injector and/or brine tube.
	Clogged basket or salt crystals on ball in air check valve.	Clean air check valve basket and/or ball.
	High pressure drop on the filter (control valve, distributors or filter media are clogged).	See paragraphs 1 and 4.
	Air is injected due to brine line not being airtight.	Check airtightness of the drain line.
	Control valve settings changed.	Increase brine stage duration.
7. Brine tank is not refilled or refilled with less water than needed.	Low supply water pressure.	Check supply water pressure.
	Clogged injector or brine tube.	Clean brine injector and/or brine tube.
	Stuck ball in the air check valve.	Clean the air check valve.
	Control valve settings changed.	Check the duration of brine tank refill and correct if necessary.
8. Excess use of salt per regeneration.	Control valve settings changed.	Decrease the amount of salt per regeneration in the control valve settings.
	Brine tank filled with excess water.	See paragraph 9.
9. Brine tank is refilled with excess water.	High main water pressure.	Check water pressure. Install pressure regulator if needed.
	Control valve settings changed.	Check the duration of brine tank refill and correct if necessary.

10. GUARANTEE

WARRANTY OBLIGATIONS

WARRANTY OBLIGATIONS

The warranty period of the water purification system is 12 months and is counted from the day of sale of the system through the retail network (unless otherwise stated in the product warranty card).

The manufacturer guarantees that this water purification system does not contain manufacturing defects and that such defects will not be detected during the warranty period specified in the warranty card, from the moment of sale from the manufacturer's warehouse or retail network, in the event that the purification system is installed and operates in accordance with the technical requirements and operating conditions. Before using the water purification system, be sure to read the instructions for connecting and operating the water purification system and the terms of the warranty obligations.

Carefully check the appearance of the water purification system and its completeness. Submit all claims regarding appearance and completeness to the seller upon receipt of the product.

We reserve the right to make changes to the design, configuration, or manufacturing technology, such changes do not impose obligations to replace or improve previously released products.

The warranty card is valid only if the model, date of sale, and clear stamps of the seller are correctly specified.

Consumer claims, in accordance with current legislation, can be submitted during the warranty period of operation, provided that the defects of the water purification system did not arise as a result of:

- non-observance of the conditions of operation and storage of systems specified in the instructions for connection and operation of the system;
- caused by transport damage, incorrect installation, careless use or misuse, connection to a power supply voltage that does not correspond to that specified in the operating instructions, failure to follow the attached connection and operating instructions.
- operation with unremedied defects, or with defects that arose as a result of maintenance or repair by persons or organizations that are not representatives of an authorized service center;
- causes independent of the manufacturer, such as: power supply voltage drops, natural phenomena, and natural disasters, fire, ingress of foreign objects (liquids) or other substances into the product;
- external and internal contamination, scratches, cracks, bruises, abrasions, and other mechanical damage that occurred during operation;
- changing the design or unauthorized opening of system nodes, when changing the serial number of the product or the date of manufacture;
- untimely replacement of elements, the terms of which are indicated in the instructions for connection and operation, as well as when using replaceable elements of other manufacturers.

10. GUARANTEE

WARRANTY OBLIGATIONS

Warranty obligations do not extend to:

- replaceable elements (cartridges, reverse osmosis membrane, carbon postfilter, mineralized, and other replaceable elements that can be equipped with the system) and sealing rings;
- components that need to be replaced as a result of their wear and tear;
- types of work, such as adjustment, cleaning, replacement of consumables, and other care of water purification systems, stipulated by the instructions for connecting and operating the product.

The manufacturer shall not be liable for any damage or any other damage, including lost profits, arising incidentally or as a result of the use or inability to use this product. The material liability of the Manufacturer under this Warranty cannot exceed the cost of the water treatment system.

In the case of an independent connection of the system, the manufacturer is not responsible and does not accept claims that may be caused by incorrect connection and incorrect operation of the system as a whole. The list of authorized service centers is indicated on the website <https://ecosoft.ua/contacts/>

All claims regarding the quality of water, taste, smell and other properties of water purified with the help of water purification systems are accepted only in the presence of a confirming protocol of analysis performed by a research accredited laboratory in accordance with the ISO 17025 standard.

Cases not covered by this Warranty are regulated by the Legislation.

11. SERIAL INFORMATION

INSTALLATION

date of installation

address and phone

accepted (customer`s name and signature)

INSTALLER

organization

date of sells

address and phone

dealer company

works accomplished (name and signature)

saller name

Only the original Warranty Registration Card with signature and stamp of the dealer is valid.

