

Osmio Fusion direct flow reverse osmosis system



Contents

1. Safety Precautions
 - 1.1 Power Safety Precautions
 - 1.2 Setup Precautions
 - 1.3 Usage Precautions

2. Product Description
 - 2.1 Appearance Sketch Map
 - 2.2 Display and Operation Interface
 - 2.3 Product Specifications

3. Start Up
 - 3.1 Introduction
 - 3.2 Connecting the feed in valve
 - 3.3 How to use quick connect fittings
 - 3.4 installing the drain saddle
 - 3.5 Connecting to the system
 - 3.6 Power Connection

4. Use
 - 4.1 Introduction
 - 4.2 Flushing
 - 4.3 Purification
 - 4.4 Dispensing Water
 - 4.5 Sleeping State
 - 4.6 Power Off

5. Filter Maintenance
 - 5.1 Introduction
 - 5.2 Filter Replacement
 - 5.3 Failure State

6. Common Usage Problem

7. Quality Assurance

8. After-Sale Service

9. Electrical Schematic Diagram

1 Safety Precautions

1.1 Power Safety Precautions

- The system should be plugged into a normal UK 3 pin plug at your home or workplace and not be used in addition to AC 220-240V, 220V.
- Should be used in a grounding socket with rated current above 10A.
- Should only be used on an electrical circuit with RCD.
- Please do not use this product if the power cord or plug is damaged or when the plug is loose.
- If there is dust or water and other foreign matter on the power plug, please wipe it clean before use.

1.2 Setup Precautions

- The system should not be installed near heating equipment, electric heating products or other high-temperature places.
- The system should not be installed in a place of possible leakage of combustible gases or near any flammable substances.
- The system should only be used indoors and positioned on a stable flat surface avoiding direct sunlight and moisture.



Take Note: Boiling water is potentially dangerous. It is the responsibility of the owner to take sensible precautions when operating the boiling water function of the system and to instruct other family members and other new users to operate it safely.

KEEP OUT OF REACH OF CHILDREN

Thank you for purchasing this product, please read this manual carefully before using the system, and keep it for future reference. If you have any questions about this machine, please call our customer service centre on **0330 113 7181**.

1.3 Usage Precautions

- On first use or if the unit has been idle for more than 2 days, run a complete cycle and discard the first batch of water produced. Install the system and then allow the machine to run until it fills the internal tanks. Dispense both ambient and hot water to ensure both hot and cold internal tanks are flushed.
- Unknown liquids or foreign objects are prohibited.
- If there is any water leakage from the machine, please disconnect the power and contact the customer service centre. Please ensure tubing at the rear of the system and the filters have been inserted correctly and fully into the system.
- If there is any abnormal sound, smell, or smoke, etc., please disconnect the power and contact the customer service centre.
- Do not disassemble or modify the system without professional guidance, please contact the customer service centre if you need support.
- Do not move this product when it is in use.
- Do not use any detergent or alcohol based cleaner to clean the product, please wipe the machine with a soft dry cloth.
- Do not grasp the water nozzle or the knob to move the machine.
- This product cannot be used by people who are physically or mentally disabled or children unless supervised. Please keep it out of reach of children.

The filters on the system need to be changed every 6 months. We offer a 1 year warranty. If you have water hardness over 250 ppm Calcium Carbonate Hardness you may need to replace the carbon and membrane more frequently. The system is designed to shut off if there is blockage in the membrane or prefilters. As the system recirculates the rejected water from the membrane, the TDS level continually rises of the water entering the membrane filter. Therefore, for those with water of higher TDS, more frequent membrane changes are required.

2 Product Description

2.1 Appearance

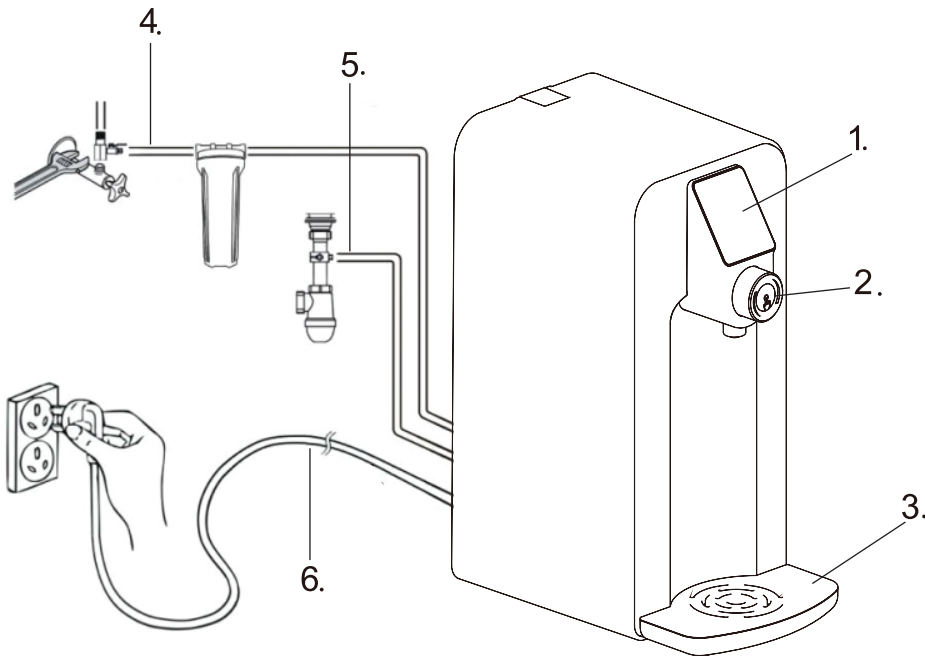

FIGURE 1

1. Display Panel
2. Control Button (Rotate & Press)
3. Drip Tray
4. Source water tubing
5. Waste water
6. Power Plug

2.2 Display and Operation Interface

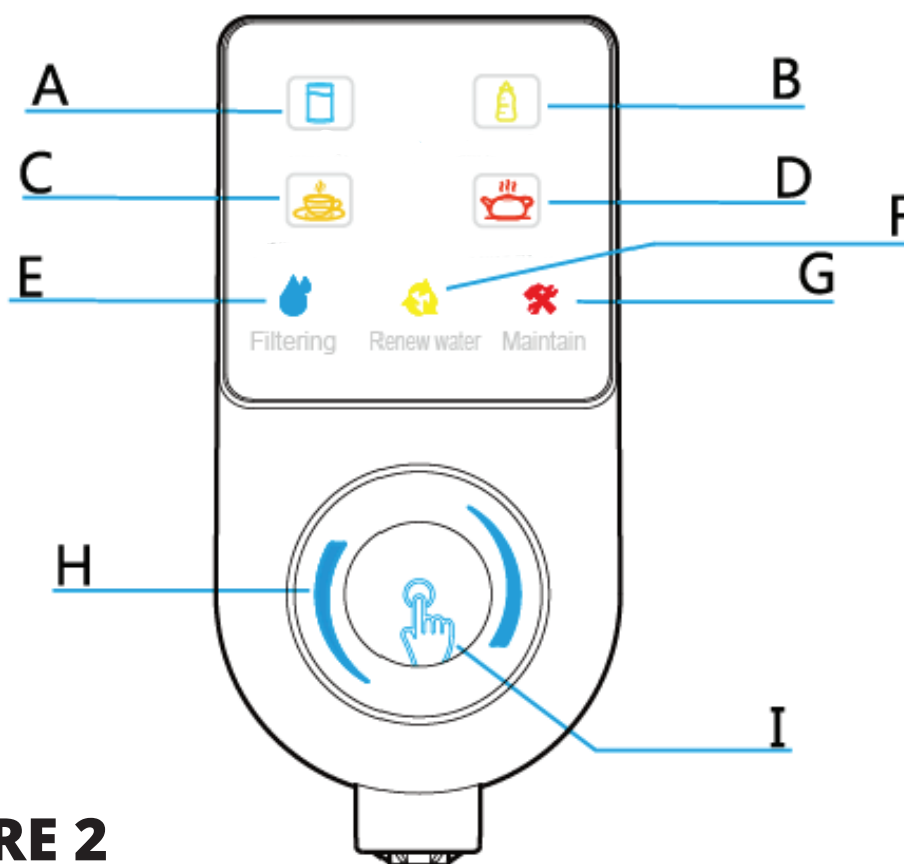

FIGURE 2

A. Normal Water

B. Warm Water (40°C-50°C)

C. Hot Water (80°C-88°C)

D. Boiled Water (90°C-98°C)

E. Filtering Water

F. Renew Water

G. Filter Maintenance

H. Rotate (Choose the Water Temp)

I. Press to Get Water

2.3 Product Specifications

Electrical Properties

Rated Voltage : 220 - 240 V

Rated Frequency : 50 Hz

Rated Power: 2200W-2600W

Heating System

Rated Heating Power: 2180W-2580W

Hot Water Capacity: 30 l/h ($\geq 90^{\circ}\text{C}$)

Filter Stages

1 - Quick-Change activated carbon filter: removes chlorine and organic impurities

2 - Quick-Change Membrane 50GPD: removes all pollutants and flavours to almost 100%

3 - Quick-Change Insertion Filters: Hygiene post filter antibacterial: removes 99% of the bacteria and viruses and improves the taste.

Volume

Pure Water Tank 1.5 L

Dimensions:

230mm Depth (320mm including drip tray)

183mm Wide

388mm Height

Weight': 5 kg

3 Start Up

3.1 Introduction

- Please place the system in a cool, ventilated, solid horizontal surface, away from any heat source.

3.2 Connecting the feed in valve - Step 1: assembling the feed in valve



The feed in valve has 1/2" male and 1/2" female and a tee off. PTFE with 7 wraps the male end of the feed in valve and the male end of the blue lever ball valve.

1) PTFE the male end of the feed in valve



2) PTFE the male end of the ball valve



3) Then using your spanner, screw the ball valve into the feed in valve and tighten it with your spanner.

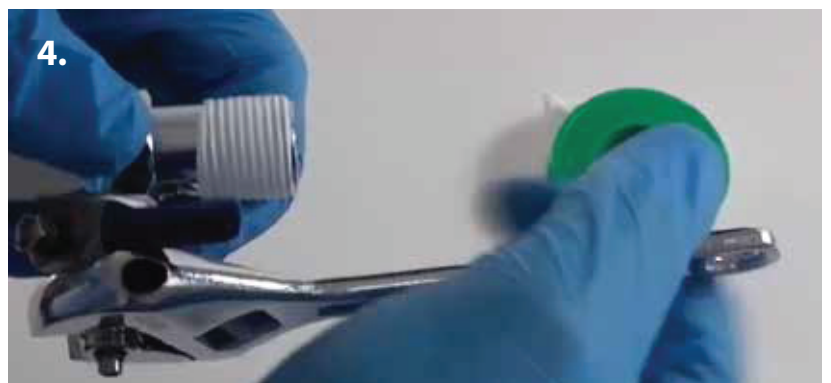

Step 2: Connecting the feed in valve



1. The Feed in valve connects to the cold hose of the existing cold tap on the sink.

Shut the water off and disconnect the existing cold water hose. If your tap does not use hoses then you can use another adaptor. Please contact us for advice.

As the Feed in valve has male on one side and female on the other side, it does not matter which way around it goes.

All you need to do is connect the feed in valve to the cold hose. Use the spanner and wrench together to make it tight.



2. To connect the ball valve to the tubing for the water filter, start by removing the nut on the blue ball valve. Then place the nut over the tubing.



3. Push the tubing ontop the stem of the ball valve. Ensure it has been pushed all the way over the little ridge.



4. Use your wrench to tighten it up. The blue lever is your on and off lever for turning the water on and off. When the blue lever.



3.3 How to Use Quick Connect Fittings

Quick connect fittings (push fittings) are used in a wide variety of plumbing, heating, electrical and fire suppression systems.

Quick connect works by inserting the tubing into a connection mechanism that deploys fastening teeth onto the tubing surface.

When opposing force is applied to the union, the teeth are forced deeper into the tubing, preventing separation of the union. The advantages of using quick connect fittings are:

- *They offer a significant time saving benefit over traditional connectors*
- *They tend to have less user failures compared to traditional connectors*
- *They require little skill or strength for their usage*
- *They do not require any tools to use and maintain them*

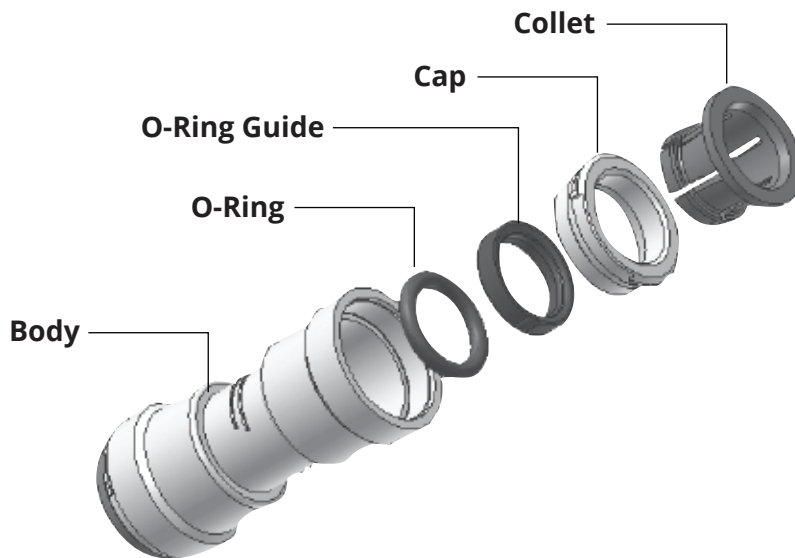

Exploded Diagram of a Quick Connect Fitting

How to Use Quick Connect Fittings

Step 1: It is essential that the outside diameter of the tubing being inserted into the fitting is completely free of scratch marks, dirt and any other material. Inspect the outside of the tubing carefully.

Step 2: It is also very important that the sliced edge of the tubing is cut cleanly. If the tubing needs to be cut, use a sharp knife or scissors. Make sure to remove all burrs or sharp edges before inserting the tubing into the fitting.

Step 3: The fitting grips the tubing before it seals. Lightly push the tubing into the fitting until the grip is felt.

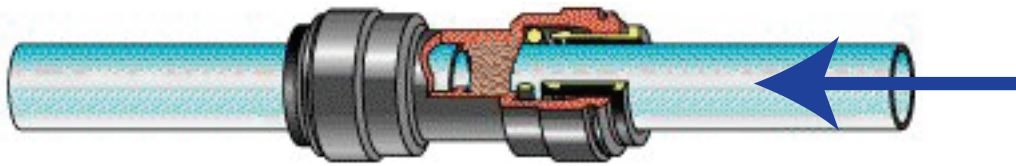

Step 4: Now push the tubing into the fitting harder until the tube stop is felt. The collet has stainless steel teeth which hold the tubing in position while the O-ring provides a permanent leak proof seal.

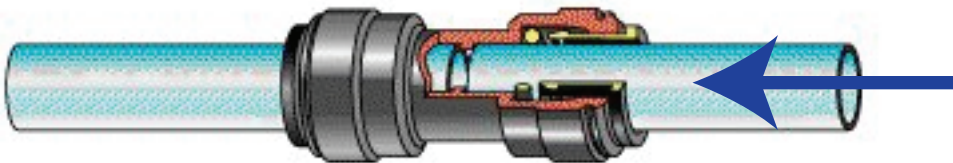

Step 5: Pull on the tubing away from the fitting and make sure it stays firmly in place. It is good practice to test the connection with pressurized water before finishing installation.

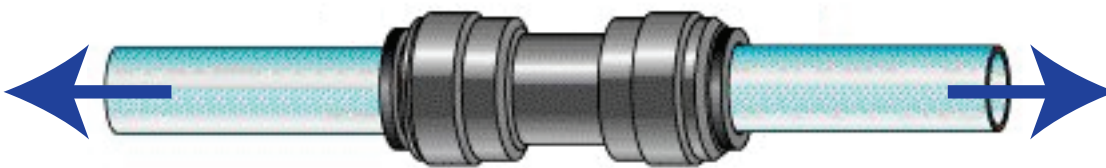

Step 6: To disconnect the tubing from the fitting, ensure that the system is depressurized first. Push in the collet squarely against the face of the fitting. With the collet held in this position, the tubing can be removed by pulling. The fitting and tubing can be reused.



3.4 Installing the drain saddle

The purpose of the drain saddle is to prevent the tubing connected to drain from popping out of place and potentially leaking where the system is installed. Please see the figure below for instructions on how to make the drain saddle connection.

- Step 1:** Select a location for the drain hole based on the design of the plumbing. The drain saddle should be installed above the u-bend if possible, on a vertical tail piece. Locate the drain saddle away from the garbage disposal to prevent potential contamination and system fouling. Please see figure below for a more detailed explanation. Use a 7 mm (1/4") drill bit to drill a small hole in the drain pipe for the drain to pass through. Clean the debris from the plumbing and hold before continuing.

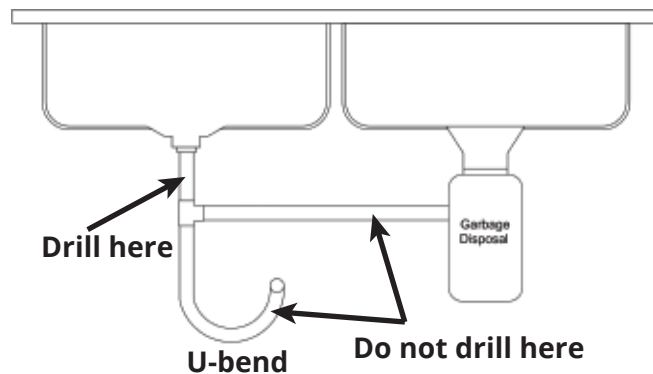

Drain Saddle Installation Location

- Step 2:** Remove the backing from the foam gasket and stick that half of the drain saddle on the drain pipe so that the holes line up (a small drill bit or other long narrow object can be used to help align correctly). Place the other half of the drain saddle on the opposite side of the drain pipe. Clamp and loosely tighten the drain saddle using the nuts and bolts included. Use a Phillips screwdriver to tighten the drain saddle. Connect the tubing from the drain saddle quick connection to the "Drain" connection on the system.

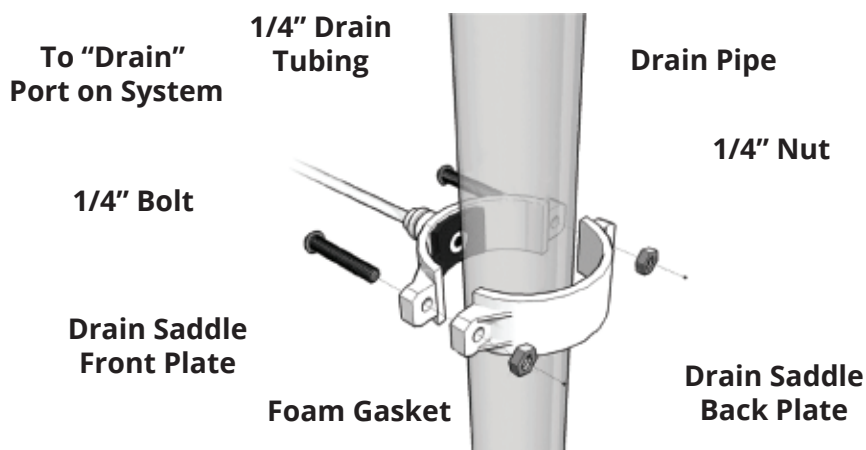

Drain Saddle Connection Diagram

3.5 Connecting to the tubing

First Remove the blanking plugs by following steps in section 3.3. Insert the tubing, which is running from the feed water, into the inlet. Place the little c-clip back into place to avoid the pushfitting disconnecting.

Insert one end of the tubing into the drain saddle (also pushfit connection) and push the other end into the outlet of the system

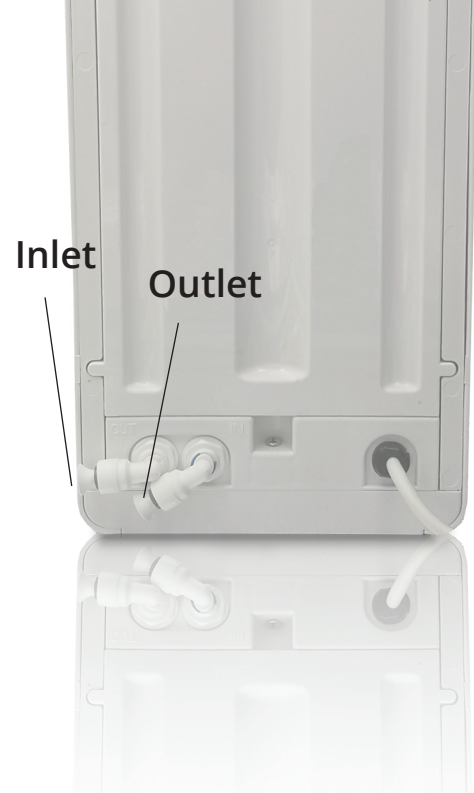

3.6 Power Connection

- Insert the power plug into the socket (see Figure 1). The system will beep and light up which indicates the machine is ready to use.

Note: This product is only suitable for AC 220-240V, 220V power supply, and should be used alone or over rated 10A with a earthed socket.

4 Usage

4.1 Introduction

- At first, produce and dispense 5 litres of water which you then dispose of by dispensing all the cold and hot water. This will flush out any loose filter media. It is normal to see black water when using new filters.
- If there is water leakage from the machine, please disconnect the power and contact the customer service centre. If there is any abnormal or unexpected sound, smell, or smoke, etc., please disconnect the power and contact the customer service centre.

4.2 Flushing

- After the setup, the machine automatically enters the flushing state and works for 120 seconds. In the flushing state, the filtering symbol of the display interface light will be on (see Figure 2).

4.3 Purification

- After flushing, the machine automatically enters the filtering state. The filtering symbol on the display interface light will be on (see Figure 2).

4.5 Dispense Water

- Place the water container on the tray (see Figure 1). Rotate the knob to select the desired water temperature (Figure 3), and then click on (or push on for 3 second) the middle part of the knob (see Figure 4) to dispense one cup (or bottle) of water. Click the knob again if you want to stop getting water. Note: the system will automatically stop water after 30 seconds if you do not click the knob and will automatically stop after 60 seconds if you hold the button for 3 seconds.

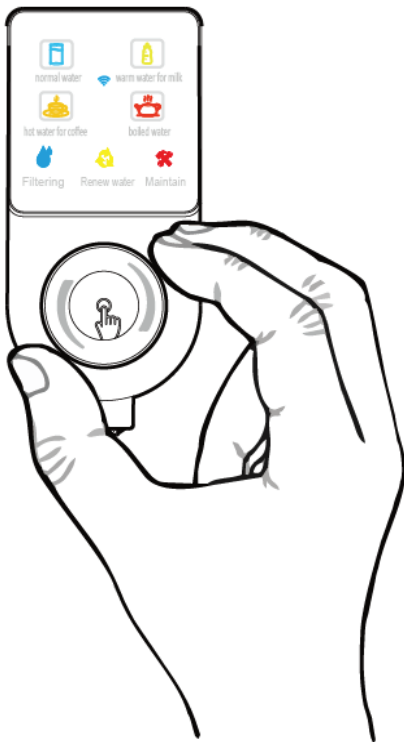

FIGURE 3

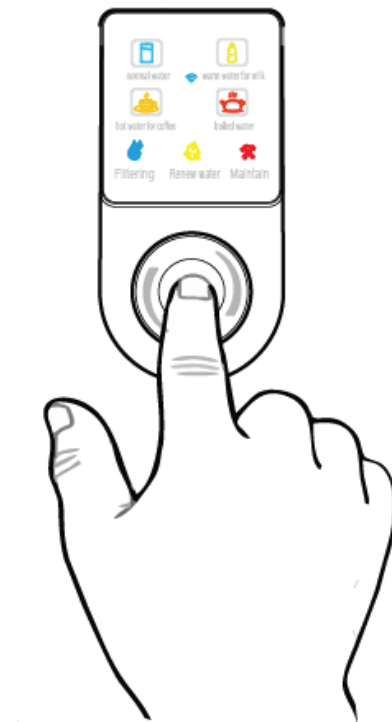

FIGURE 4

4.6 Sleeping state

- The system will automatically enter sleeping state when it is idle for more than 1 hour. If there is any knob or button operation, it will immediately return to service and then flush for 20 seconds.

4.7 Power off

- The system will automatically power off if the machine stays in sleeping mode for 1 hour. If there is any knob or button operation, it will power on automatically.

5 Filter maintenance

5.1 Introduction

First skip to section 5.2.4 to read about sanitisation and come back to this section.

Use the company's certified filters. Disconnect the power. Do not disassemble or attempt to modify this product.

5.2 Replacement of the carbon filter, reverse osmosis and post filter

Step 1: Open the back panel

Step 2: Place the back panel to the side

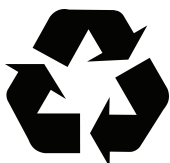
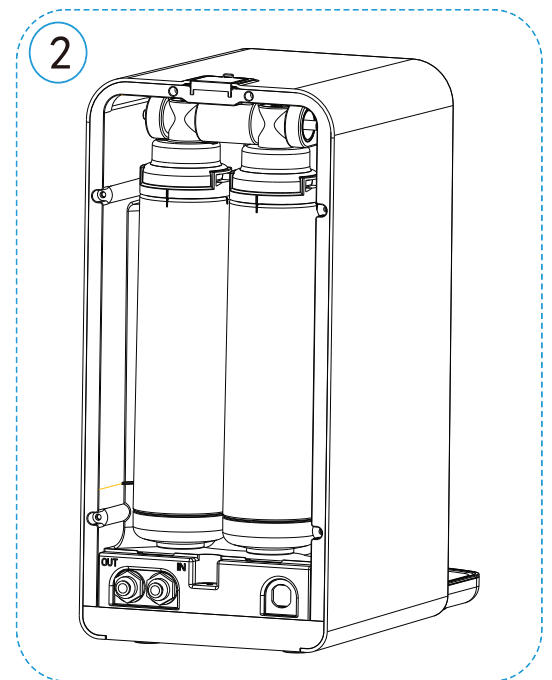
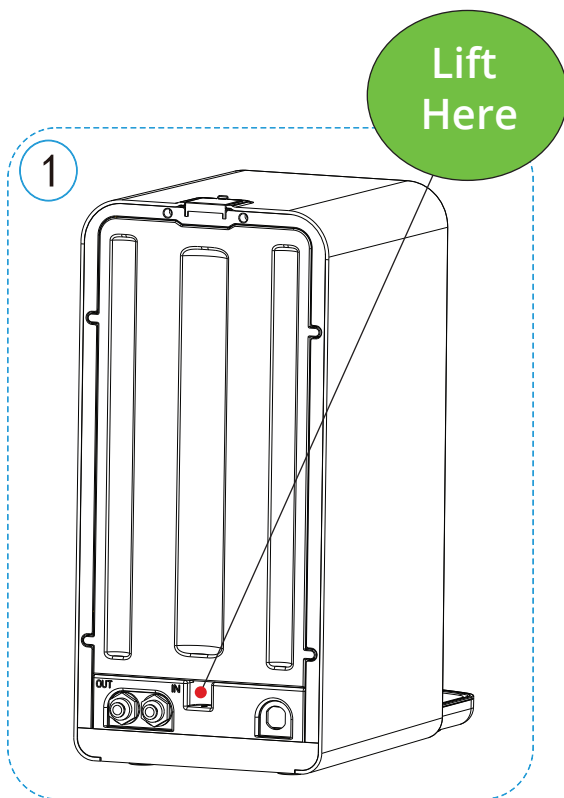

Help your environment and put all used filters in recycled plastic waste

5.2 Replacement of the carbon filter, reverse osmosis and post filter,

STEP 3 Starting at the base of the filter, tilt the filter towards you slightly and rotate the Carbon Filter and Membrane filter clockwise and remove them from the head.

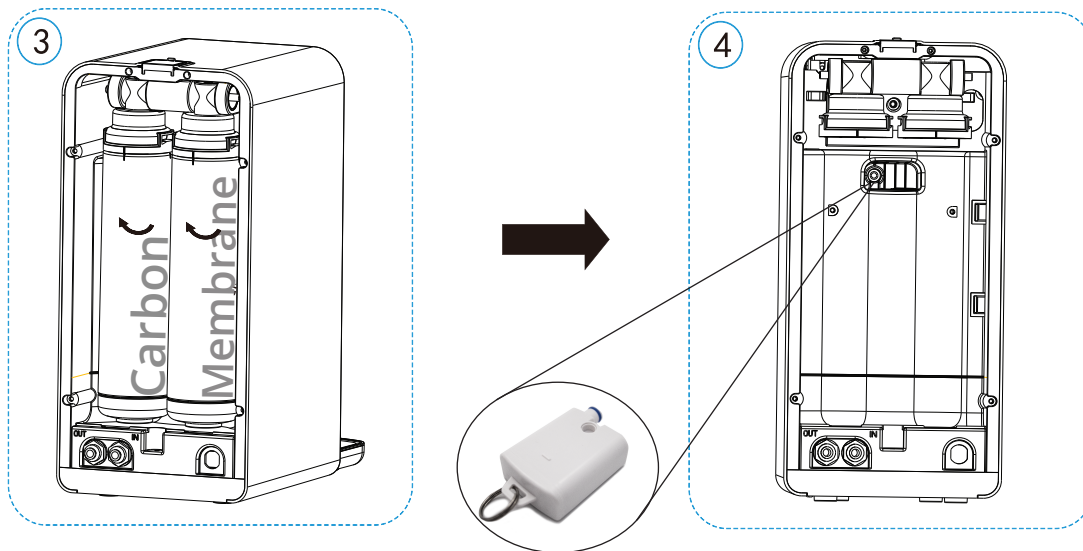

STEP 4 Pull out the Post Filter slowly with your finger and insert a new one fully.

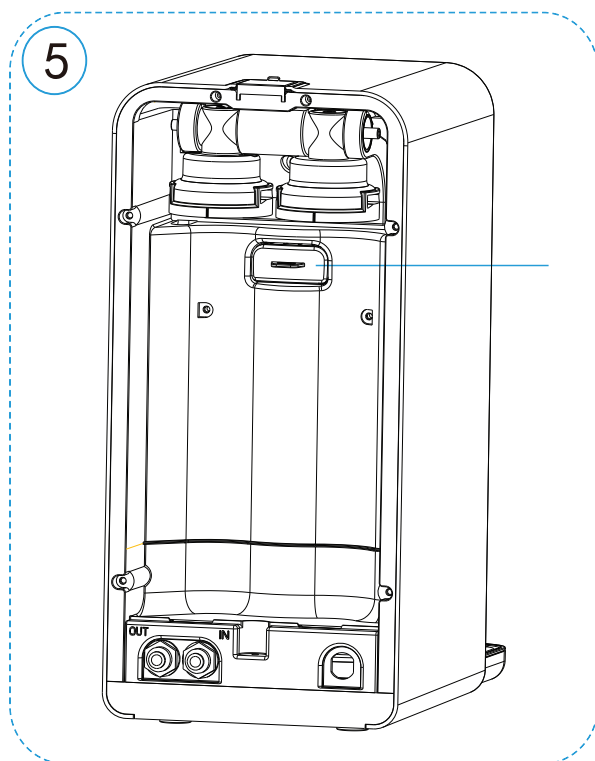

STEP 5 Insert the new insertion post filter into the place of the old one.

Ensure that the filter is in correctly. It should fit snugly and not stick out.

5.2 Replacement of the carbon filter, reverse osmosis and post filter,

STEP 6 Start with the new Carbon Filter so the label is on the left hand side twist the filter on anticlockwise. Repeat the same with the Membrane Filter.

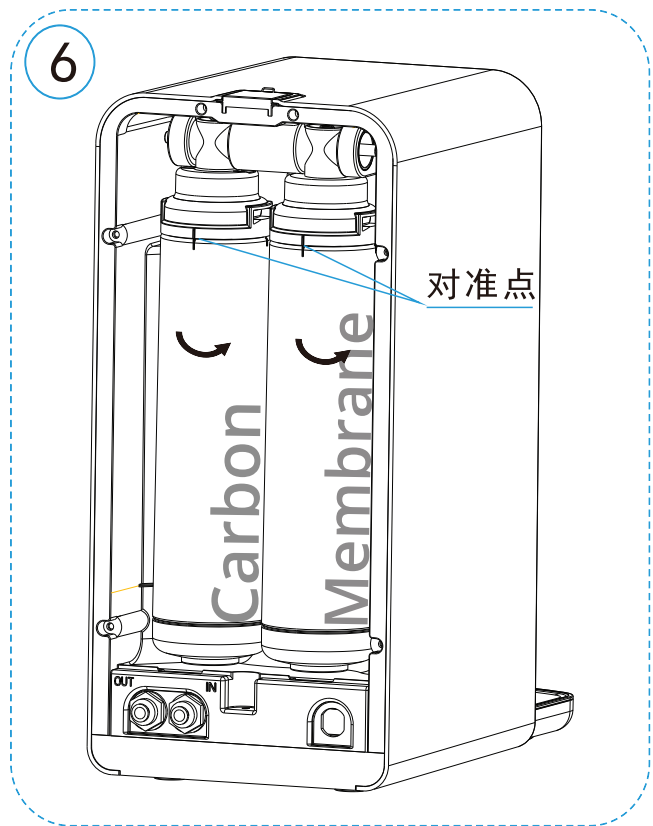

STEP 7 Place the back panel into its place at the rear of the system.

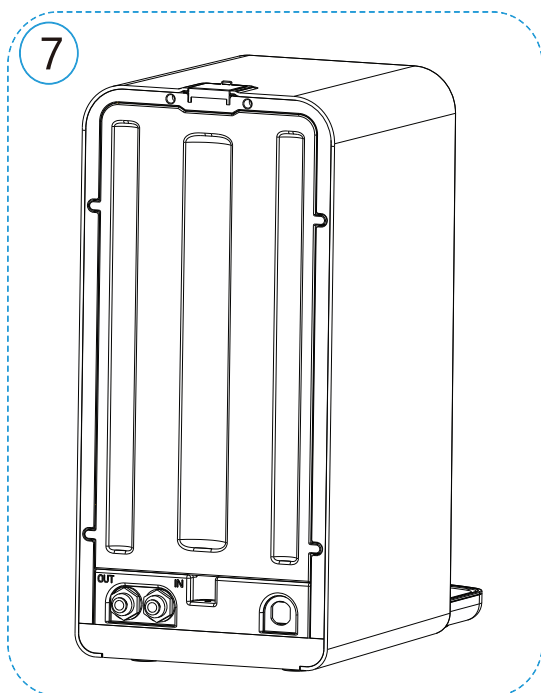

STEP 8 Press and hold the button and at the same time connect the power plug to the socket. The beep sound indicates the filter reset has completed.

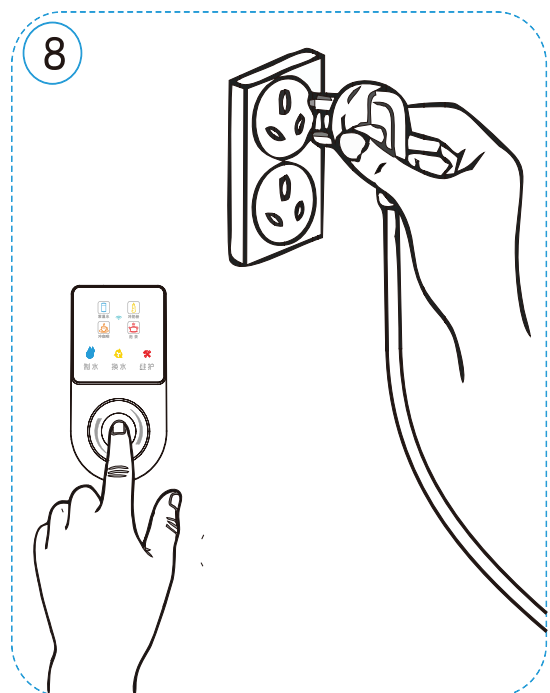

5.2.4 Sanitisation

We suggest sanitising the system every 6 months prior to the filter change. Contact your dealer to order the Fusion Sanitisation Kit.

1) Shut of the feed water by turning the lever of the feed in valve. Press the button repeatedly to dispense all the water out of the internal RO storage tank.

2) Remove all 3 filters (Carbon Block, RO Membrane and the Post Remineralisation Filter). Insert the blank three filters in their place.

3) Instert the small piece of 1/4" tubing into the WHITE push fitting of the sanitising housing. Disconnect the 1/4" INLET tubing (this is the tubing from the SUPPLY valve that goes to the system) and connect the this to the BLUE side of the housing. NOTE: the housing has an arrow to show you the direction of flow and it must be placed the correct way round, ensuring the arrow is pointing in the flow direction.back on, add two Milton tablets, then wait for 5 minutes until dissolved.

4) Place a milton tablet into the small housing and shut it. Open the feed in valve to allow the water to fill up the housing and the machine. Let the machine fill up and shut the feed in valve.

5)Let the system sit like this 30-60 minutes. Dispense all the water in the internal tank by pressing and holding the button. Disconnect the extra tubing and sanitisation housing from the set up. Reconnect the tubing into the inlet of the system.

6) Remove the sanitisation cartridges and replace them with new filters and install a new set of filters.

7)After sanitisation the fastest way to clean all the sanitising fluid from the internal tank is to press the button repeatedly to dispense water until no more can be dispensed from the internal RO storage tank, then allow the system 10-15 minutes for the system to refill the internal RO tank. Repeat this step until no more sterilising solution can be detected...(usually 2 or 3 times). We recommend you watch our short video of the sterilisation process.

5.3 Failure state

5.3.1 Purification exception

The system will show the purification exception state if the machine purifies water for a long time and cannot stop, all the four temperature icons on the display will flash. The machine may make louder noises leading up to this. This happens when the Carbon Filter is blocked, and also the RO Membrane might be blocked. First change the carbon block and see if the production rate goes back to normal and if not, then also change the RO membrane. Also change the Sediment Filter and Remineralisation Filter too if they are 6 months old.

5.3.2 Burning alarm

The system enters the dry state if the heater works without water or the temperature exceeds the safe setting, the icon for hot water (80°C-88°C) will blink, the machine can only dispense normal temperature water but cannot dispense any kind of hot water. Solution: please contact our helpdesk.

6 Common usage problems

If you have some problems during the usage, please check the problems by following the guide below.

Usage Problems	Likely Cause	Suggested Solution
Cannot dispense ambient temperature water	Power is disconnected. Not pressing on the right place.	Check the power plug is loose or not in place. Press the button again.
	Water shortage in purified water tank, "filtering" icon blinking.	Check the connections on the rear of the filter. Also check tubing for kinks.
Cannot dispense hot water	Power has only just been connected and the system needs time to warm up	Dispense a little bit of the normal temp water first then wait for 15 minutes and then dispense hot water.
	The machine is in the state of "burn alarm".	Dispense ambient temperature water several times then retry dispensing hot water.
	Purified Water shortage "filtering" icon blinking.	Wait for moment until the "filtering" icon light is on all the time then dispense hot water.
Machine does not filter	Tubing leading up to the filter is blocked	Check tubing for any debris or blockages
	Tubing leading up to the filtration system is kinked	Straighten out the tubing.

Usage Problems	Likely Cause	Suggested Solution
Abnormal sound during the filtering.	Air blocked in the water system.	Turn the system on and off and try to flush air from the system. Sometimes air may take a few days to clear
	Filters are blocked and need replacement.	Change the RO Membrane Filter first and if this does not solve the problem then a do a complete filter change. If the system was run in this state permanent damage can be made to the pump.
Water leakage.	Drip Tray is full of water.	Empty the tray.
	Pushfitting loose at rear of machine	Check push-fittings and secure correctly with clips.
	Internal water leakage.	Power off and contact customer service.
Odour in the water	Brand new system	Dispense 5 litres of water before using the system.
	Unused for more than 5 days	Dispense 5 litres of water before using the system.
	Filters over 6 months old	Change all the filters

7 Quality assurance

The guarantee is valid for the UK and Republic of Ireland as well as the following EU countries: **Austria, Belgium, Czech republic, Denmark, France, Germany, Netherlands, Luxemburg, Slovakia, Slovenia, Spain, Italy, and Hungary.**

The guarantee becomes effective at the date of purchase or at the date of delivery if this is later.

Proof of purchase is required under the terms of the guarantee.

The guarantee provides benefits in addition to your statutory consumer rights.

Our 1 Year Warranty covers the repair or replacement of all or part of your system if your system is found to be defective due to faulty materials or manufacture within 1 year of purchase. We also offer a 5 year free repair for customers in the UK. **Customers from Ireland and the EU countries listed above can also take advantage of this service but they are required to ship the system to us (no free returns).**

If any part is no longer available, or out of manufacture, Osmio reserve the right to replace it with a suitable alternative.

Do not disassemble the system yourself as this will void your warranty and the company will not assume any responsibility for the resulting quality problems or accidents.

The system is BPA-free and made to top manufacturing specifications and is CE certified.

The company will charge fully for parts and maintenance if it exceeds the guarantee period or the machine breaks down due to damage. Please keep your sales invoice as proof of purchase.

Osmio does not guarantee the repair or replacement of a product that has failed for any of the following reasons:

- Faulty installation, repairs or alterations not in accordance with the installation guide.
- Normal wear and tear. We suggest the system should be replaced after 5 years.
- Accidental damage or faults caused by negligent use or care; misuse; neglect; careless operation and failure to use the system in accordance with the operating guidelines.
- Failure to maintain the water filters in accordance with the instructions.
- The use of anything other than genuine Osmio replacement parts, including the water filter cartridges.
- The use of the filter system for anything other than normal domestic household purposes.
- Failures of, or failures caused by, parts not supplied as part of the genuine Osmio system.
- We offer free shipping and free repairs (if the system has been sent to us)

8 After-sale service

Our products have 1 year guarantee (for repair, replacement or compensation of faulty products). If the product you bought has any quality problem, please bring your invoice and to the dealer's shop, exchange or refund service will be offered within 30 days, maintenance service will be offered within 5 years. Customer service hotline: 0330 113 7181

9 Electrical & Schematic Diagram

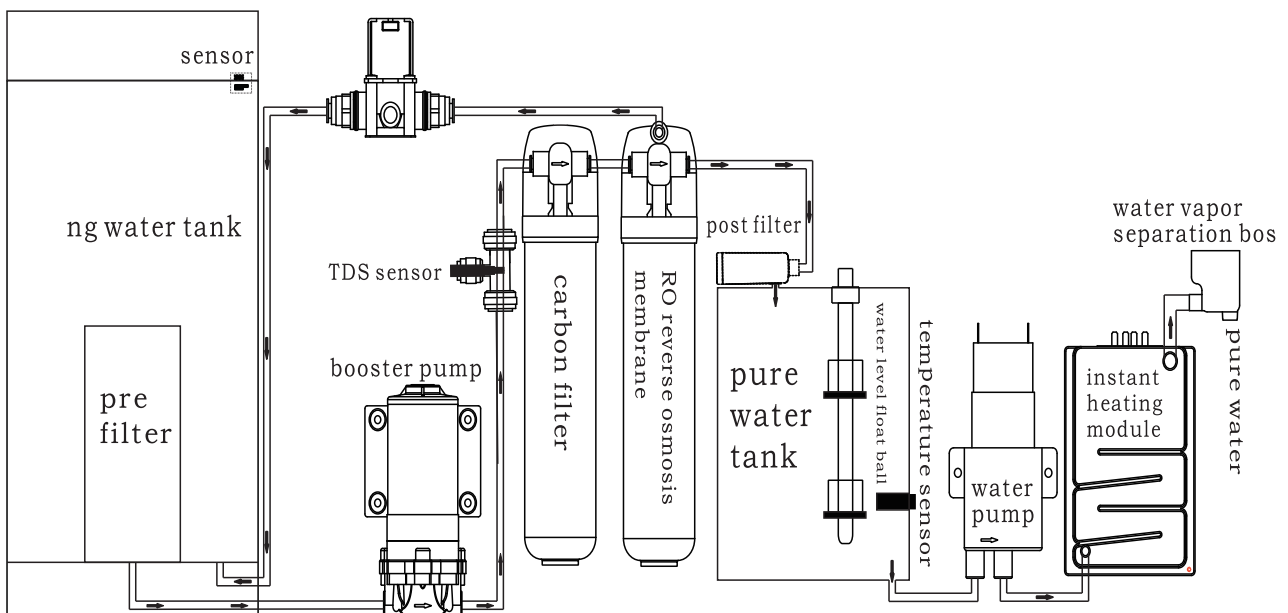
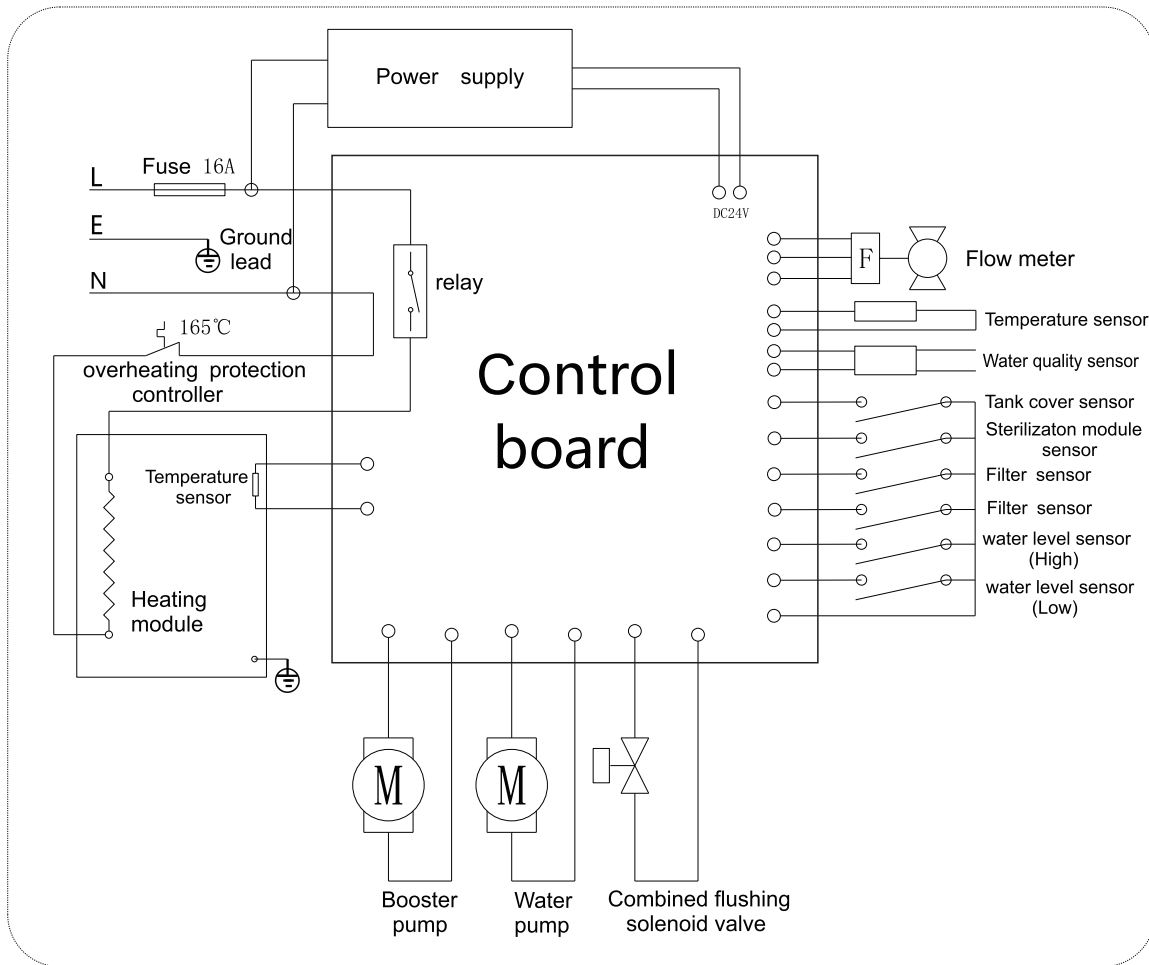

Declaration of conformity



This product may not be treated as household waste. Instead it shall be handed over to the applicable collection point for the recycling of electrical and electronic equipment. By ensuring this product is disposed of correctly, you will help prevent potential negative consequences for the environment and human health, which could otherwise be caused by inappropriate waste handling of this product.

For more detailed information about recycling of this product, please contact your local city office, your household waste disposal service or the shop where you purchased the product.

IEC 60335-2-15 Safety of household and similar electrical appliances. Part 2: Particular requirements for appliances for heating liquids:

Report Number..... : STL/R 01601-BC164902

Certificate of Conformity for Quality Management System ISO9001: 2015 Standard in the scope of design and manufacture of water purifiers.

NSF Testing Parameters and Standards

- 1) Determination of extractive residue, density and melting point for propylene homopolymer according to US FDA 21 CFR 177.1520
- 2) Determination of extractives residue according to US FDA 21 CFR 177.1850
- 3) Determination of extractive residue according to US FDA 21 CFR 177.2600
- 4) Determination of identification test, heavy metal(as Pb),lead and water extractables test refer to FCC standard

The Osmio Fusion Direct Flow Reverse Osmosis System © Osmio Solutions Ltd. All Rights Reserved